

DANEO 400

Hybrid signal analyzer for
power utility automation systems



DANEO 400 – hybrid measurement

DANEO 400 is a hybrid measurement system that records and analyzes all conventional signals (voltages, currents, hard wired binary status signals) and messages on the communication network in a digital substation. It measures signals from both of these worlds and can provide information to assess their proper coordination. With this device you can easily keep track of what is going on in the substation by obtaining information on the operational status and communication.

Easy configuration and control

Easily configure and control one or more DANEO 400 units with the PC software DANEO Control. For controlling a single device, a selected feature set is also available via the built-in DANEO 400 web interface.

The control can be safely performed over the substation communication network without impairing the function of the substation automation system (SAS).

Distributed recording with multiple units

A measurement system with multiple DANEO 400 units obtains a time aligned view on signals covering the entire scope of a distributed SAS. All acquisition units are accurately time synchronized, using the Precision Time Protocol (PTP) according to IEEE 1588-2008.



Network interfaces

Control interfaces

Extension interfaces



system

Fields of application

DANEO 400 is a useful tool that covers the whole life-cycle of a protection automation and control (PAC) system.

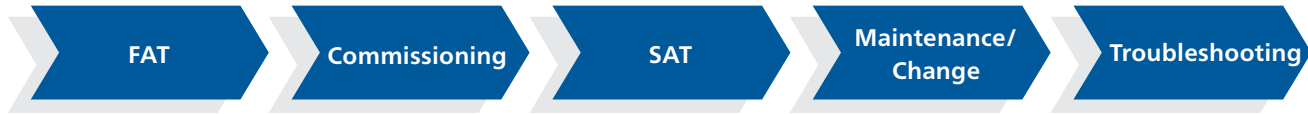

DANEO 400 can be used in all kinds of different PAC systems and network topologies:

- > Hybrid substation with conventional signals and network communication
- > Local area network (LAN) in local substations
- > Wide area network (WAN) between substations
- > Redundancy network topologies (e.g. HSR and PRP)

Main use cases

- > Fault recording (classical and hybrid)
- > Verification of IEC 61850 communication
- > Supervision of network traffic
- > Assessment of network performance

Mass storage interface

4 x binary outputs

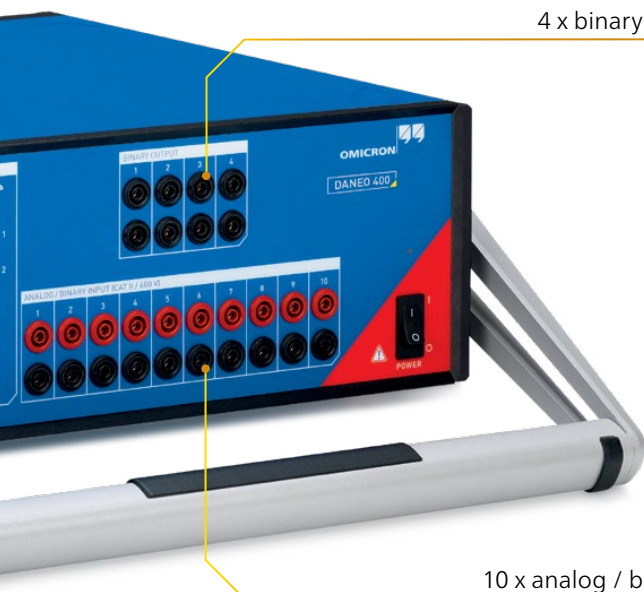

10 x analog / binary inputs

Your benefits

- > Easy to operate with DANEO Control software or web interface
- > Easy access to IEC 61850 information
- > Simultaneous processing of analog/ binary signals and network traffic
- > Analysis of distributed systems
- > Autonomous supervision of real-time traffic
- > Traces sporadic events in trouble-shooting

www.omicronenergy.com/DANEO400

One device – multiple use cases

Fault Recording (classical and hybrid)

The occurrence of a malfunction in a PAC system is often unpredictable. Problems occur infrequently and under conditions which are not always known. When they do occur it is critical to resolve such issues. In troubleshooting you often need to react to situations without any preparation and you have to improvise without access to the full documentation of the system. DANE0 400 helps you to find out what may be causing the malfunction.

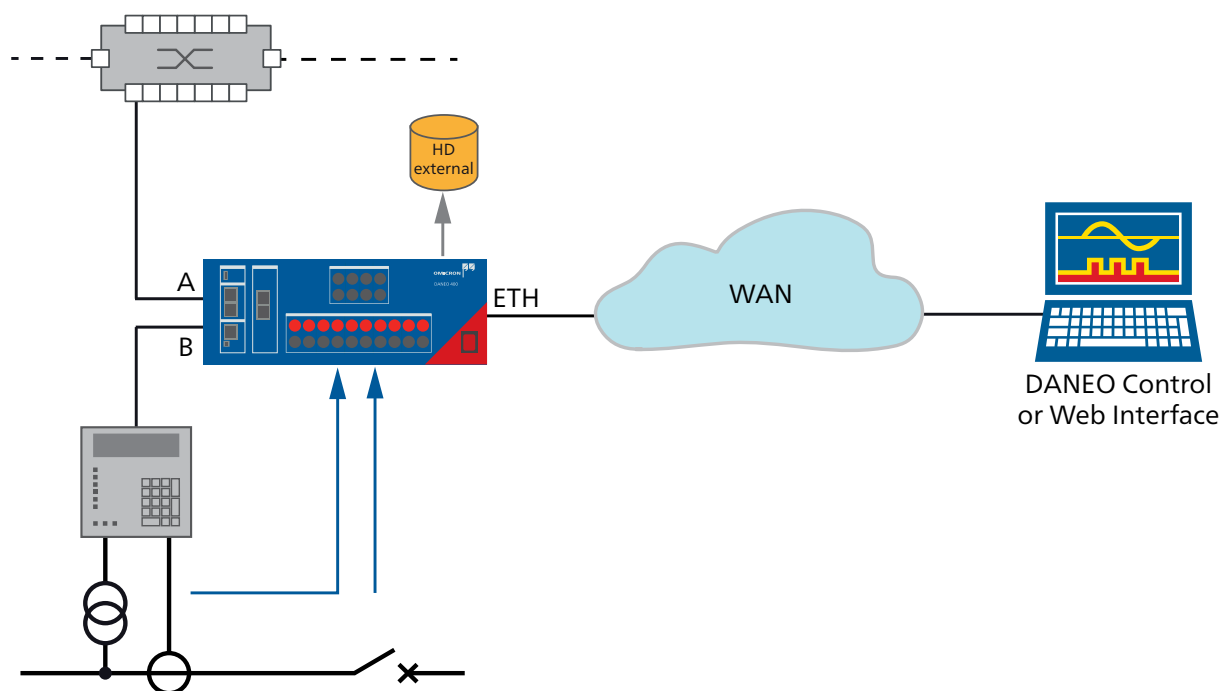

Unattended operation

The device works unattended in permanent or semi-permanent test setups. The detection of predefined trigger conditions starts the recording of signals and network traffic. The device rearms itself to detect another occurrence of the fault and creates multiple recordings autonomously.

External storage

If large amounts of data are expected, an external hard drive can be connected for storing the recordings.

Remote control

With a remote connection to the DANE0 400 you can check the device status and download recordings for analysis. There is also a built-in web interface for easy access to the device with a web-browser.

Verification of IEC 61850 communication

The IEC 61850 communication is a mission critical part of a PAC system. DANE0 400 supports you to easily verify, prove and document that your protection and control devices are working and communicating properly.

The description of the communication system in the standardized IEC 61850 substation configuration language (SCL) format serves as the basis for the verifications. It is verified that the IEC 61850 server of all IEDs are available and the substation network traffic is actually present on the communication network as defined.

As devices are put into operation one by one during commissioning, the verification can be performed incrementally without re-executing all the checks for all devices already verified.

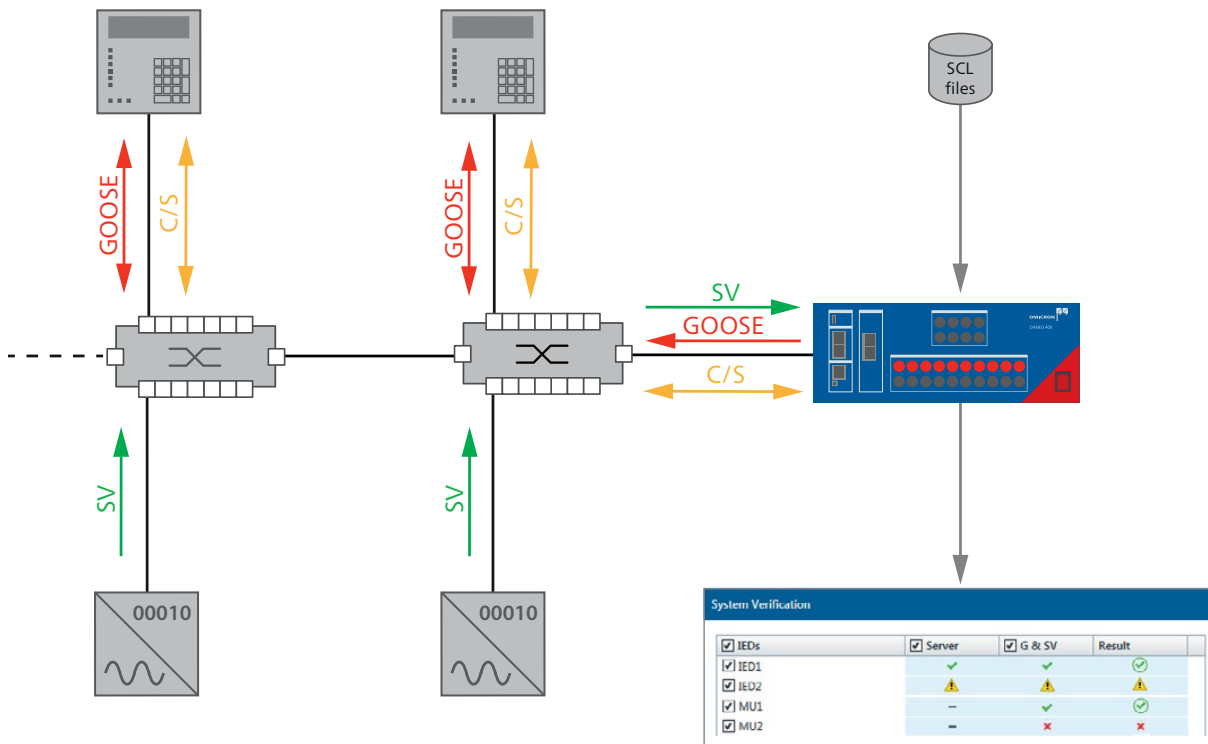

Debugging differences

If devices do not perform as desired, detailed information is provided for further investigation and debugging. The differences between the configuration and the traffic on the network is clearly visualized side by side.

Find orphan elements

All found GOOSE messages or Sampled Values streams which are not defined in the SCL files are listed as orphan elements.

One device – multiple use cases

Supervision of network traffic

During the normal operation of a PAC system, the IEC61850 network traffic is supervised so that any issues are detected immediately. The supervision is based on the SCL definition and constantly evaluates all network packets of GOOSE messages and Sampled Values streams.

The DANE0 400 detects abnormalities in the network traffic and automatically logs all events with the corresponding detailed information (e.g. lost samples, GOOSE timing problems, PTP time synchronization issues...). The event severity and category helps to filter and analyze the entries in the event log.

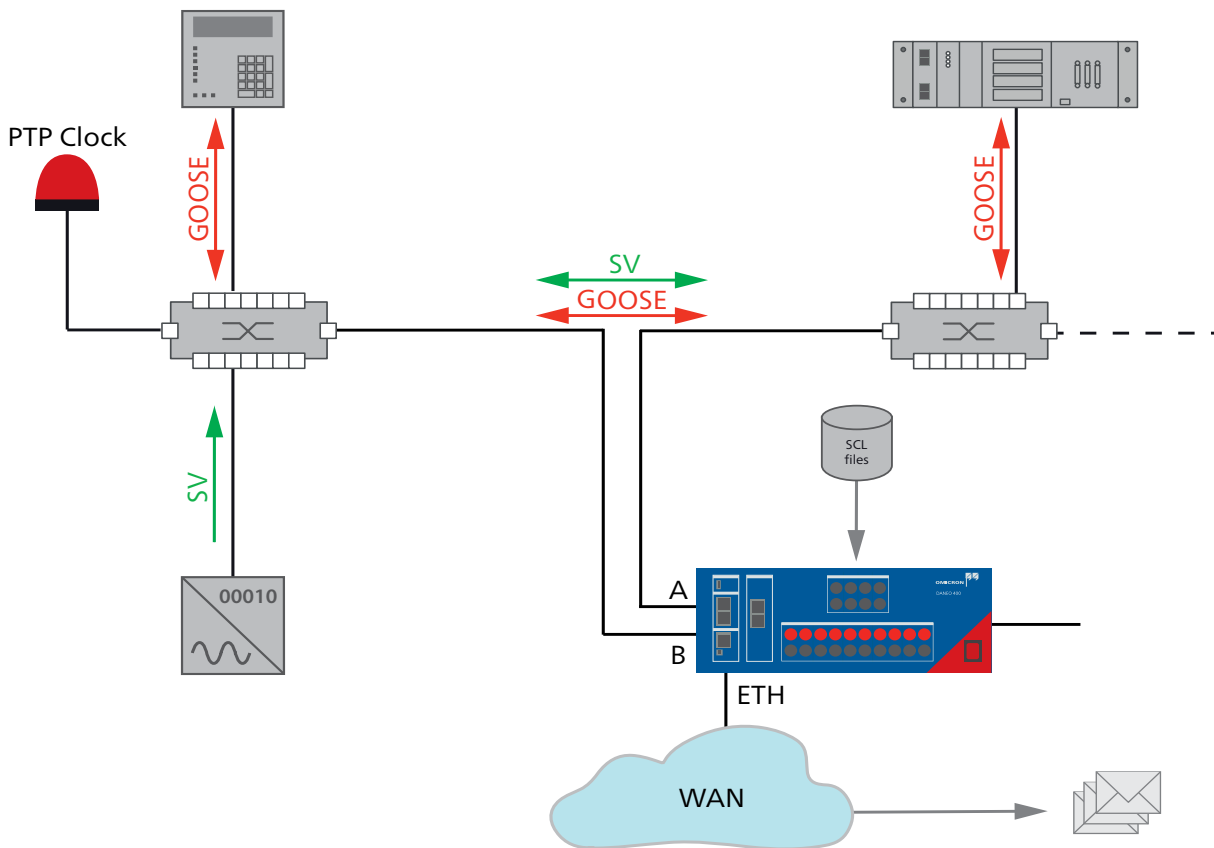

Actions

The occurrence of events can trigger recordings of the relevant data or send email notifications to inform the operating staff. Multiple actions with different event filters can be configured.

Network TAP mode

The DANE0 400 can be connected in passive TAP mode to the substation network. Thus, it can obtain all traffic on a link without the requirement to configure traffic monitoring in the Ethernet switches.

Network performance assessment

The correct functioning of the communication network is an essential precondition for the optimal performance of a PAC system. Consequently, the performance and load of the communication network needs to be measured and assessed on its own. Depending on the communication architecture and technologies deployed, different approaches are applicable.

DANE0 400 measures and assesses the transfer of status information (e.g. GOOSE messages) within a local substation network or between substations. All involved devices are configured and controlled with the DANE0 Control software, even if they are connected over a wide area network (WAN).

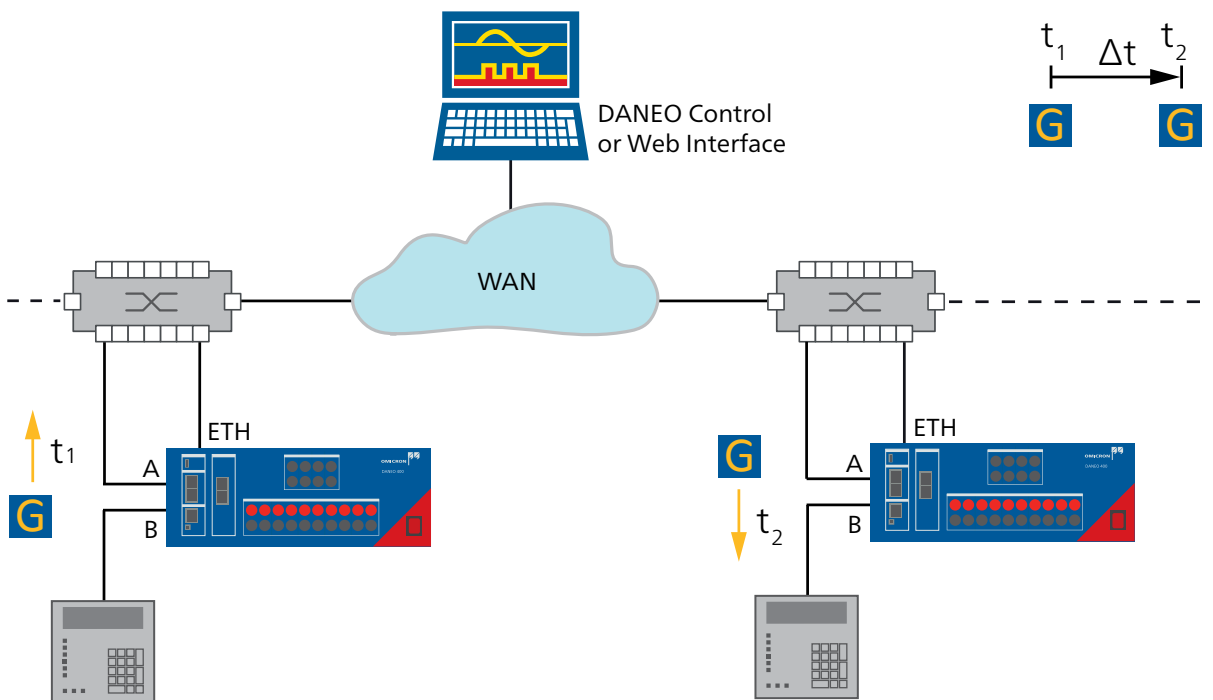

Redundancy networks

There are often redundancy mechanisms (e.g. HSR and PRP) used in PAC systems. DANE0 400 can also measure packet timings in such network topologies.

DANEO Control – data acquisition and analysis

The innovative DANEO Control is the PC software to easily control your DANEO 400 measurement system and analyze your recordings. It is divided into an Acquisition and Analysis workspace. All configurations and results can be saved in files, printed or stored in PDF/RTF format.

Data acquisition



In the Acquisition workspace you configure your measurement devices and IEDs of the system under test. You can import IED configurations from SCL files and find GOOSE and SV orphans on the network. The whole test setup is visualized in a network diagram. The IEC 61850 communication can easily be verified against the configuration and the supervisor detects abnormalities during the operation. Measurements for phase and power systems, binaries, and network load are available in the device signal pool. All signals can be observed live, used in trigger conditions, and recorded.

Acquisition tools:

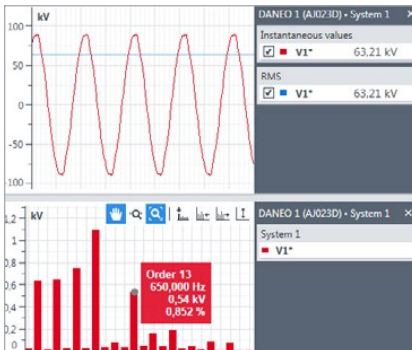

Observation

The actual values and the most recent history of all signals in the pool are shown:

- > Measurement live values and recent history
- > Instantaneous value observation
- > Phasor diagrams
- > Relative phase values
- > Harmonics spectrum view



Recording

All signals from the pool and the network traffic are recorded. A recording is started manually or by a defined trigger condition.

- > Signals selection
- > Traffic filters configuration
- > Trigger condition and recording length settings
- > Post trigger action configuration
- > Storage location definition

Date and Time	Device	Category
2015-10-16 15:49:35.049	DANEO 1 (AJ023D)	GOOSE
2015-10-16 15:48:44.576	DANEO 1 (AJ023D)	Device
2015-10-16 15:48:43.109	DANEO 1 (AJ023D)	GOOSE
2015-10-16 15:48:34.576	DANEO 1 (AJ023D)	Device

Severity	Error
Date and Time	2015-10-16 15:49:35.049
Device	DANEO 1 (AJ023D)
Category	GOOSE
Type	Out of sequence

Supervision

The network traffic is constantly supervised and the occurred events are logged in the devices.

- > Live event list
- > Details for selected events
- > Actions for specific events to trigger recordings or send email notifications

Data analysis



In the Analysis workspace you can analyze your recordings, view all supervisor events, and assess the performance of the substation network. It is easy to find and select the recordings and supervisor events on the time line. The data is collected from your devices or from local folders. If recordings are too large, just crop it for analyzing. Simply export your recordings into COMTADE and PCAP files for analyzing the data with other tools.

Analysis tools:

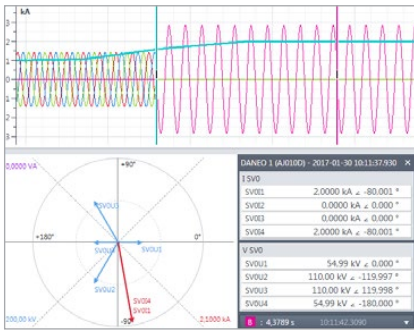

Time Signal Analysis

All recorded signals are available in an aggregated and time-aligned view for analysing the results.

- > Show time signals and phasors in diagrams
- > Harmonic spectrum view
- > Offer cursor values and calculations
- > GOOSE packet details for mapped binary signals
- > Post-calculated traffic signals for recorded PCAP files

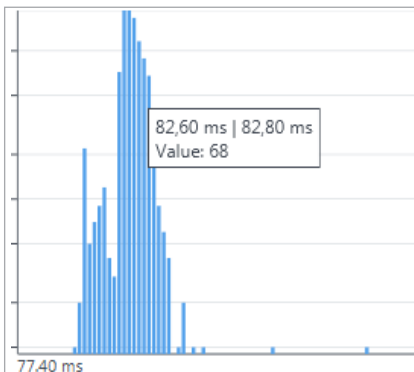

Propagation Delay Analysis

Calculation of propagation delay statistics for any kind of packets between two different locations in the network.

- > Selection of network packet and direction
- > Propagation delay statistic values (min, max, average, standard deviation)
- > Histogram diagram of delay values

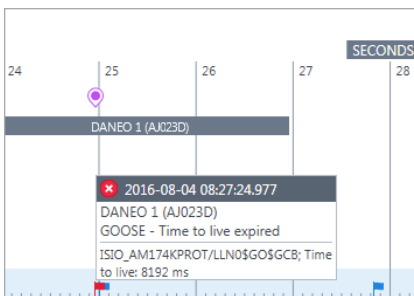

Supervisor Event Analysis

All events are shown on a time line together with the recordings. They can be analyzed, saved, and documented together.

- > Events on time line
- > Selected event in list with all details
- > User comments for documentation

Operating options

Web interface

The DANE0 400 has a built-in web interface. Certain functions of a single device can be accessed by simply connecting with a web-browser. The supported feature set focuses on functions related to the traffic on the communication network. The device status can be checked and available recordings can be downloaded for further analysis. It is also possible to publish up to three Sampled Values streams.

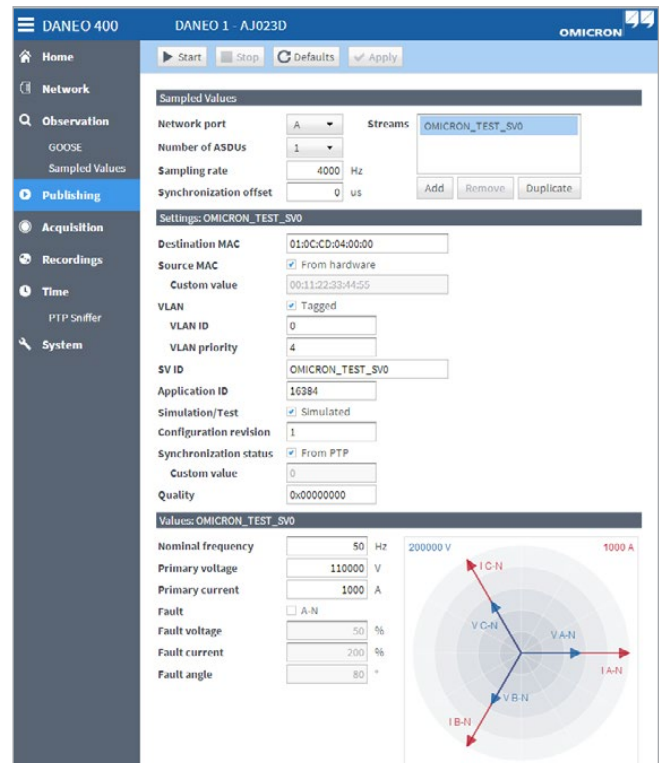

DANE0 400 web interface

Flexible housing

The housing of the DANE0 400 is very flexible. It can be configured for different working positions by rotating and moving the device handle.

For placing the DANE0 400 on the floor, the handle can be used as a stand. If the handle is not required (for example, stacking of multiple devices) you can easily move it to the rear of the DANE0 400.



DANE0 400 handle used as floor stand

Accessories

EXB1 binary I/O extension unit

The EXB1 extends the I/O capabilities of the DANEO 400 with 8 binary inputs and 8 binary outputs. The EXB1 units are connected to the DANEO 400 main unit via the extension interfaces.

www.omicronenergy.com/products/exb1



EMCON 200 Ethernet media converter

The PTP transparent media converter EMCON 200 is used to connect the DANEO 400 to the optical fiber networks. It is powered over Ethernet (PoE) and SFP transceiver modules offer flexible configurations.

www.omicronenergy.com/emcon200



PTP grandmaster clock

In some cases a time synchronization of the involved DANEO devices is a must (e.g. distributed recording with multiple units). Dedicated PTP grandmaster clocks are required if the PTP protocol is not available yet on the communication network. OMICRON offers the suitable accessories CMGPS 588 and OTMC 100p.

www.omicronenergy.com/cmgps588

www.omicron-lab.com/otmc100



Technical Specifications

DANEO 400

Network interfaces

Network ports (A,B)	2 Ethernet ports 10/100/1000 Base-TX (RJ45); configurable as network TAP
---------------------	--

Control interfaces

Control port (ETH)	1 Ethernet port 10/100/1000 Base-TX (RJ45)
USB port	1 USB 2.0 device port; High-Speed (Type B)

Mass storage interface

USB port	1 USB 3.0 host port; SuperSpeed (Type A)
----------	--

Extension interfaces

Extension ports (OUT 1,2)	2 EtherCAT® ports (RJ45)
---------------------------	--------------------------

Analog inputs

Number	max. 10 (shared with binary inputs)
Sampling frequency	10 kHz or 40 kHz
Nominal ranges	10 mV, 100 mV, 1 V, 10 V, 100 V, 600 V
Measurement category	CAT II / 600 V CAT III / 300 V CAT IV / 150 V

Binary inputs

Number	max. 10 (shared with analog inputs)
Level detection	Potential-free contacts or DC voltage compared to threshold voltage
Input ranges	10 V (-10 V ... 10 V); 100 V (-100 V ... 100 V); 600 V (-600 V ... 600 V) default: 600 V
Sampling frequency	10 kHz
Time resolution	100 µs

Binary outputs

Number	4
--------	---

Internal storage

Technology	Solid State Disc (SSD)
Capacity	approx. 58 GB

Power supply

Voltage; nominal	100 – 240 VAC, 1-phase
Frequency; nominal	50/60 Hz
Power consumption max.	100 W

Environmental conditions

Operating temperature	0 °C ... +50 °C +32 °F ... +122 °F
Storage and transportation	-25 °C ... +70 °C -13 °F ... +158 °F

Mechanics

Dimensions (W x H x D, without handle)	345 mm x 140 mm x 390 mm 13.6 in x 5.7 in x 15.4 in
Weight	7.0 kg 15.4 lbs
Ingress protection	IP30 according to EN 60529

Ordering options



	Description	Ordering No.
DANEO 400 Basic	Signal Analyzer for Power Utility Automation Systems. Measuring and recording conventional (analog and binary) signals	VEESC1700
DANEO 400 Standard	Hybrid Signal Analyzer for Power Utility Automation Systems. Measuring and recording conventional (analog and binary) signals and traffic from power utility communication networks (IEC 61850 GOOSE and Sampled Values)	VEESC1701
Upgrade	from DANEO 400 Basic to DANEO 400 Standard	VEESC1711
EXB1	Binary I/O extension unit for DANEO 400 which offers an additional eight binary inputs and outputs	VEESC1710
EMCON 200	Ethernet media converter used for connecting optical fiber and twisted pair copper Ethernet networks	VEESC1712
CMGPS 588	Antenna-integrated IEEE 1588-2008/PTP grandmaster clock optimized for outdoor usage supporting the power profile according to IEEE C37.238-2011	VEHZ3004
OTMC 100p portable	Antenna-integrated IEEE 1588-2008/PTP grandmaster clock and NTP time server for applications in the power industry supporting the power profile according to IEEE C37.238-2011	VEESC1800



A strong and safe connection

Welcome to the team

At OMICRON you can always depend on an experienced team that actively supports you and an infrastructure that you can rely on. We always listen attentively in order to understand your needs so that we can offer you the best possible solutions. We strive for lasting partnerships and ensure that you can continue to rely on your product long after you've purchased it. In order to do this, we focus on quality, the transfer of knowledge and unique customer support.

Aditya, David and Fabian are able to tell you about the services we have available for you and why it pays to be part of the team.



Aditya Taneja
Application Specialist

Solutions you can rely on...

... developed with experience, passion and an innovative approach that we use to continually set groundbreaking standards in our industry sector.

We invest more than 15 % of the total turnover in research and development so that we can even guarantee the reliable use of the latest technology and methods in the future.

Our comprehensive product care concept also guarantees that your investment in our solutions – like free software updates – pays off in the long term.





David Negron
OMICRON Academy



We share our knowledge...

... by maintaining a constant dialogue with users and experts. Some examples of this are our customer events and conferences that take place all over the world and our collaboration with numerous standardization committees.

We also make our knowledge available to you in the customer section of our website in the form of application reports, specialized articles and articles in the discussion forum. With the OMICRON Academy, we also provide a wide spectrum of training possibilities and assist you with Start-up training and free webinars.



Fabian Kolb
Technical Support

24/7 support

When rapid assistance is required...

... our excellent level of support is always appreciated. You can reach the highly-qualified and committed technicians in our customer support department 24 hours a day, seven days a week – and it's completely free. We deal with repair services and service features in a fair and non-bureaucratic manner.

We can help minimize your downtime by lending you equipment from a readily available plant at one of our service centers in your area. A comprehensive offer of services for consulting, testing and diagnostics completes our range of services.

OMICRON is an international company serving the electrical power industry with innovative testing and diagnostic solutions. The application of OMICRON products allows users to assess the condition of the primary and secondary equipment on their systems with complete confidence. Services offered in the area of consulting, commissioning, testing, diagnosis and training make the product range complete.

Customers in more than 160 countries rely on the company's ability to supply leading-edge technology of excellent quality. Service centers on all continents provide a broad base of knowledge and extraordinary customer support. All of this together with our strong network of sales partners is what has made our company a market leader in the electrical power industry.

For more information, additional literature, and detailed contact information of our worldwide offices please visit our website.