

# Microwave Moisture Measurement System

## Type 5505

COMM-connect Microwave Moisture Measurement System (MMMS) is designed to measure the moisture percentage in dry matter feedstock for biomass fired power plants. The measurement is realized using fixed sets of transmitters and receivers. The typical installation is measuring 2 pieces "Hesston 4800" straw bales measured side by side, giving a nominal distance of 2x120 cm (2x4 ft.). On each side of each set of bales there are three measurement units spread symmetrical around the centerlines. The MMMS is a highly flexible system, and multiple topologies for measuring moisture content is possible. Contact your local COMM-connect representative, to enquire about possibilities for your application.

The measurement units consists of microwave transmitters with a directional antennas mounted on one side and microwave receivers with directional antennas mounted on the opposite side of the bales/containers.

The measurement of the moisture percentage relies on microwave absorption in the water within the dry matter. The absorption leads to microwave attenuation, and this attenuation is measured by a logarithmic detector. The moisture percentage is given from the measured attenuation value when compared to attenuation values measured at a certified laboratory.



### Typical applications:

- Biomass fired Power Plants
- Storage facilities for Biomass feedstock
- Forklifts handling biomass feedstock
- Conveyor systems for feedstock handling
- Biomass fuel mapping

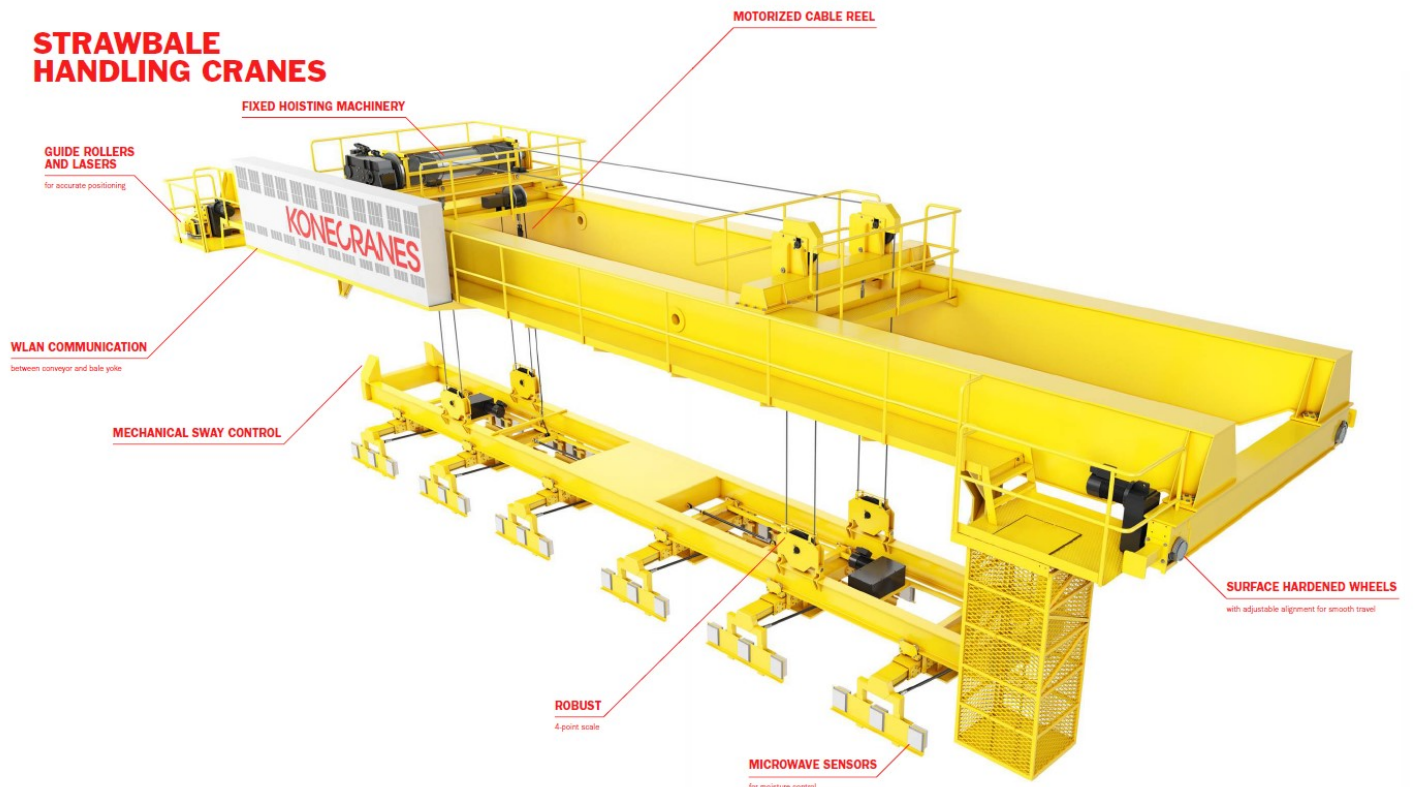

COMM-connect A/S reserves the right to change prices and specifications without prior notice

**System description:**

The System for measuring a full Truck and Trailer set is mounted onto the crane with six pickups. On each pickup there are three transmitters and three receivers totaling 18 transmitters and 18 receivers. All units are connected to a multiplexer in a star configuration.

The multiplexer has communication with the 18 receiver and receives the measured attenuation and status information. The multiplexer converts the attenuation value received into a moisture percentage.

The Multiplexer communicates with the central warehouse computer. The central warehouse computer has control over all functions of the measurement cycle.

The central warehouse computer initiates the measurement by issuing a command to the multiplexer. Commands executed by the multiplexer select the individual units, times the microwave measurement and returns the measured value.

All the units are calibrated in absolute values and supplied with interface plugs. The units can be interchanged or replaced during installation or for diagnostic purposes.

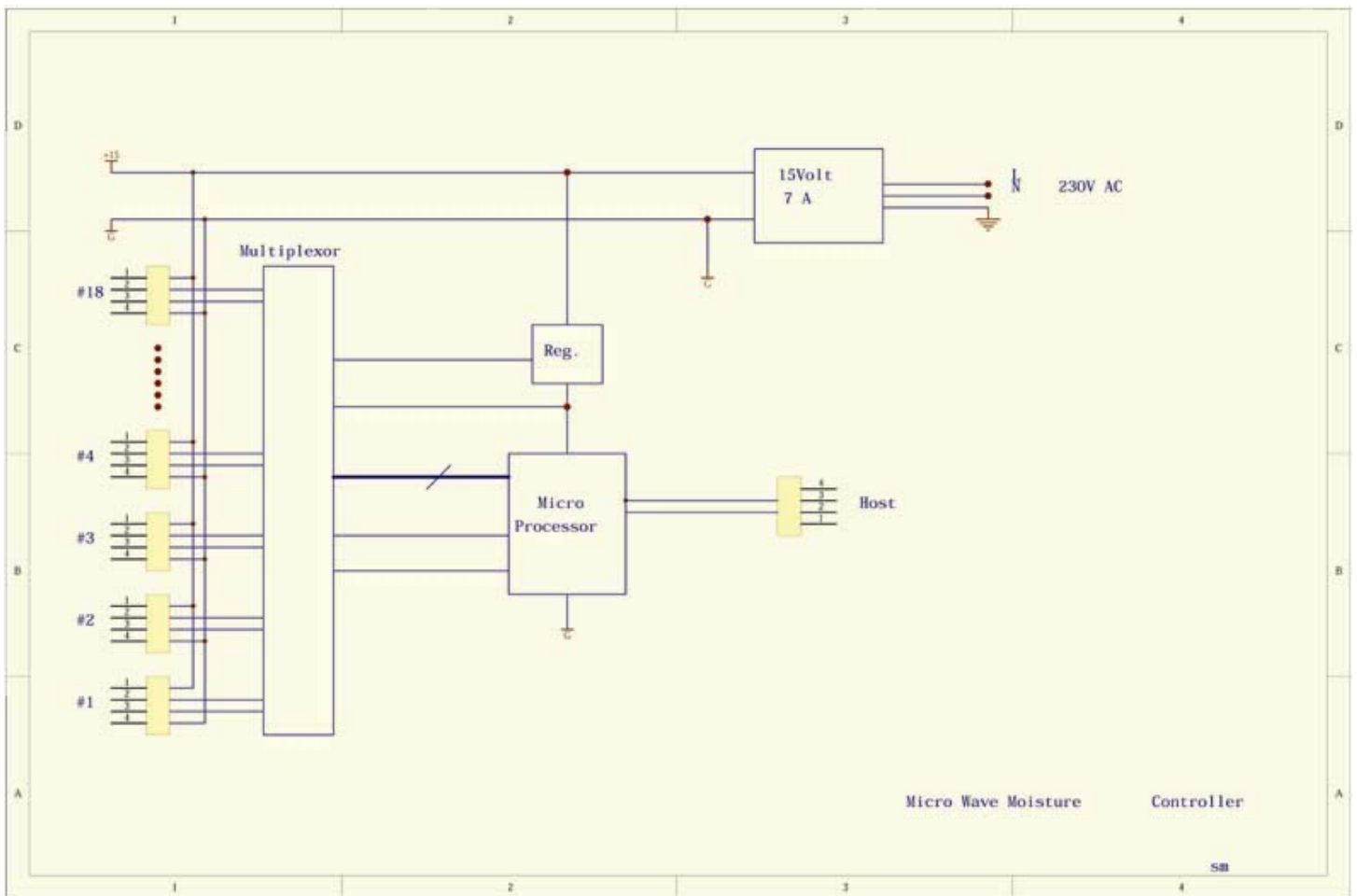

**Measurement topologies:**

As the first page indicated, the typical installation of a MMMS, measures two straw bales side-by-side, and returns the average moisture level for each sensor set. However, multiple topologies are possible, as the system is not dependent on the specific mounting. Below you'll find an inspirational set of topologies based on our customer feedback, and projects still underway.

**Straight sensor line**

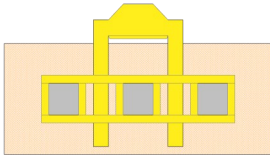

**Single Bale**

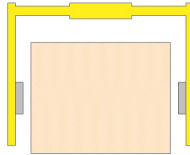

**Double Bale**



**Skewed sensor line:**

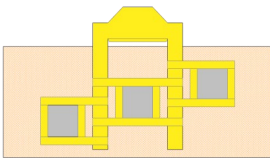

**Single Bale**

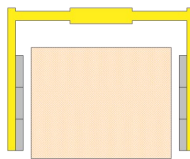

**Double Bale**

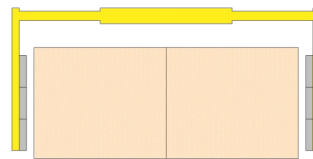

**3D Conveyor scan:**

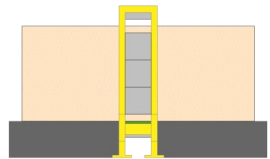

**Single Bale**

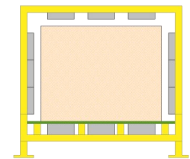

**Top-Bottom+Side scan:**

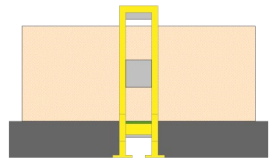

**Single Bale**

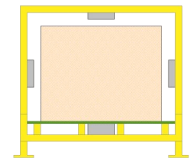

**Single point scan:**

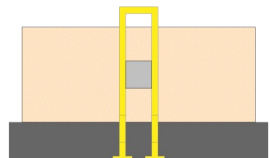

**Single Bale**

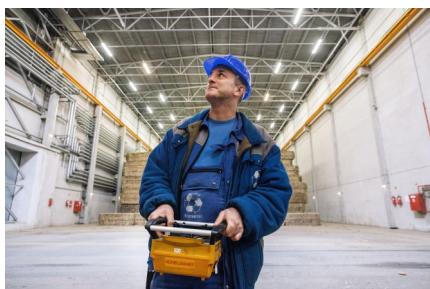
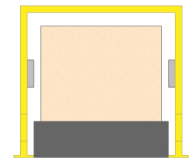

**Storage and Handling flows:**

Depending on the physical layout of the plant site, various options related to the operational flow is possible. Below you will find some inspiration for the design of your logistical flow.

**Truck and trailer:**

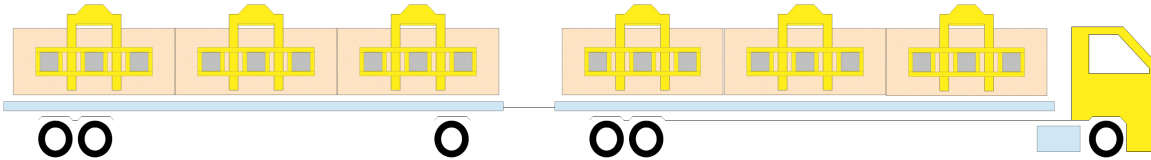

**Semi truck and trailer:**

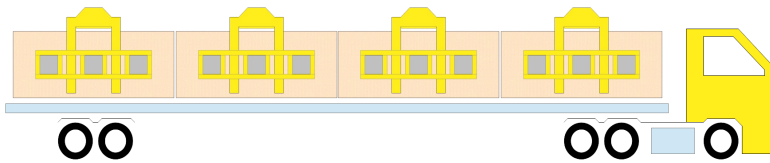

**KC Liftruck for single bale handling:**



**3D scan type with Pre- and/or Postloading:**

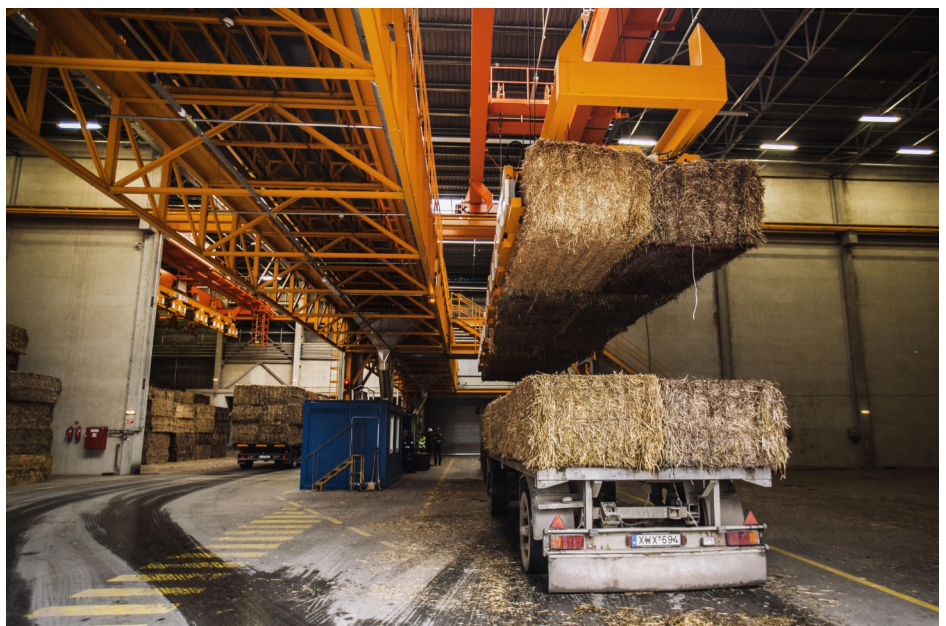
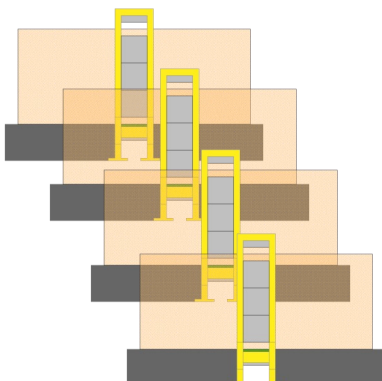

**Feedstock types:**

- Straw bales
- Hay bales
- Corn stock bales
- Rice bales
- Rape seed bales
- Flax straw bales
- Wood pellets
- Wood chips
- General dry matter feedstock

**Features:****Standard**

- Measurement range, 10-27%
- Configurable polynomial or linear conversion curve
- Configurable upper and lower limits
- Configurable resolution (0 or 1 decimal)
- Communication fault reporting
- Equipment check reporting
- Version check

**Optional**

- KONECRANES TruConnect
- Single sensor detailed measurement
- Single grabber detailed measurement
- Single sensor disabling
- Single grabber disabling
- Ambient temperature
- Ambient Relative humidity %
- Weight/Mass curve correction
- Material/Container/Bale size setting
- Datalogger (All events)
- Bale presence detect (Conveyor systems)
- Web Management Interface
- Lower measurement range, 4-10%
- Upper measurement range, 27-50%
- Touch screen control interface
- PC based control interface

**Specifications:**

System:	
Measurement ranges:	Standard: 10-27% Extended lower: 4-10% Extended upper: 27-50%
Multiplexer (5505MUX):	
Power supply:	230 VAC 150V/A 15 VDC for Tx & Rx Transmitter approx. 500 mA each Receivers approx. 100 mA each
Communication, units:	RS485, 2 Wire for Tx & Rx.
Communication, Mux:	RS485, 4 Wire full duplex to Distribution/Ops management system
Communication type:	Asynchronous ASCII 2400 Baud 8 Data No Parity 1 stop bit.
Transmitter:	
Transmitter frequency:	2,4GHz ISM Band (2457,6MHz)
Transmit power:	750mW $\pm$ 2%
Antenna specifications:	E plane $\pm$ 17°, H plane $\pm$ 19°
Receiver:	
Receiver frequency:	2,4GHz ISM Band
Temperature stability:	5ppm °C
Logarithmic detector:	>80dB range
Linearity:	better than $\pm$ 0.5dB
Antenna specifications:	E plane $\pm$ 17° H plane $\pm$ 19°
Control signal to transmitter:	Open Collector
Communication to Mux:	RS485, 2 Wire
Environment:	
Temperature:	-20° C to +50° C
Sealing:	IP66
EMC:	89/336EEC 92/31EEC EN55011 EN50082
Interface connections:	
Transmitter and Receiver:	Neutrik XLR plugs.
Multiplexer:	PG Glands Terminal strips with plugs.
Boxes:	
Transmitter and Receiver:	Polycarbonate
Size:	H: 300mm x W: 230mm x D: 110mm H: 11.81" x W: 9.06" x D: 4.33"
Multiplexer:	Painted Steel cabinet
Size:	H: 300mm x B: 300mm x D: 150mm H: 11.81" x W: 11.81" x D: 5.91"

## Ordering details:

Item	Content	COMM-connect ordering code
Measurement System for 1 doublebale pickup	1 x 5505_MUX2 3 x 5505_RX3 3 x 5505_TX4	5505_3P_KIT
Measurement System for 2 doublebale pickup	1 x 5505_MUX2 3 x 5505_RX3 3 x 5505_TX4	5505_6P_KIT
Measurement System for 3 doublebale pickup	1 x 5505_MUX2 3 x 5505_RX3 3 x 5505_TX4	5505_9P_KIT
Measurement System for 4 doublebale pickup	1 x 5505_MUX2 3 x 5505_RX3 3 x 5505_TX4	5505_12P_KIT
Measurement System for 5 doublebale pickup	1 x 5505_MUX2 3 x 5505_RX3 3 x 5505_TX4	5505_15P_KIT
Measurement System for 6 doublebale pickup	1 x 5505_MUX2 3 x 5505_RX3 3 x 5505_TX4	5505_18P_KIT
Replacement units		
Multiplexer	1 x 5505_MUX2	5505_MUX2
Sensor set	1 x 5505_RX3 1 x 5505_TX4	5505_RX3_TX4

## Contact details:

### COMM-connect A/S

Raasigvangen 2  
DK-3550 Slangerup  
Denmark

Att.: Thomas Pedersen  
Phone: +45 48 28 82 82

Web: <http://www.comm-connect.com>

Email: [sales@comm-connect.com](mailto:sales@comm-connect.com)